

PASSION MULTI DECK REF. CASE - P2

LENGTHS; 38"L , 48"L, 60"L, 74"L , 94"L

DEPTH: 32"

HEIGHT: 54½ "



STANDARD FEATURES

1. LED top light.
2. Tempered glass shelves c/w LED lights.
3. Tilt out front curved safety glass.
4. Front glass defogging system.
5. Clear anodized framework.
6. Thermo pane sliding doors.
7. Exterior plastic laminate - black.
8. Interior Plastic laminate - black.
9. Fan assisted self-contained refrigeration with hot gas condensate pan.
10. Smart digital temperature control with auto defrost.
11. 8 ' plug and cord.
12. 1 year parts and labour warranty.
13. CSA SPE-1000 code for electrical safety.

OPTIONAL FEATURES

1. Custom exterior plastic laminate of choice.
2. Powder coated framework of choice.
3. Adjustable legs (consult factory for size).
4. Heavy duty casters(height increase by 4").
5. Bumpers on front and sides.
6. Side glass defogging system.
7. Remote refrigeration.
8. Call factory for other options.



SMART COOLING CONCEPTS INC.

14 MELANIE DR., UNIT 11, BRAMPTON, ON, CANADA, L6T 4L3
Tell: 905-458-5340, Fax: 905-458-4424, Toll Free: 1-855-458-5840
smartcoolingconcepts.com. email:garysohi@smartcoolingconcepts.com

PASSION MULTI DECK REF. CASE - P2

PROJECT _____ ITEM _____ QTY _____

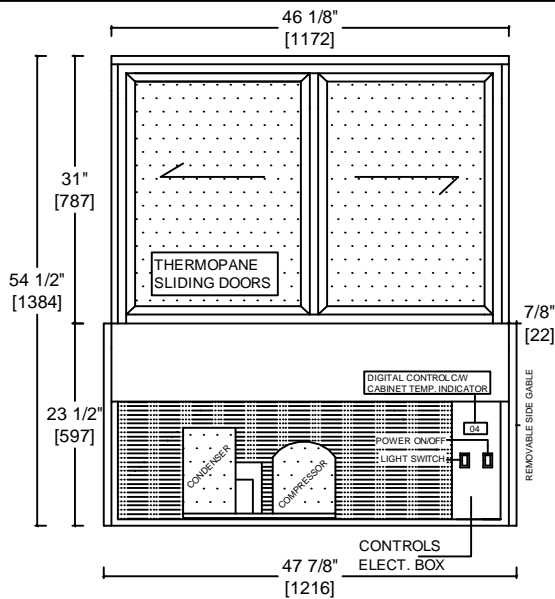
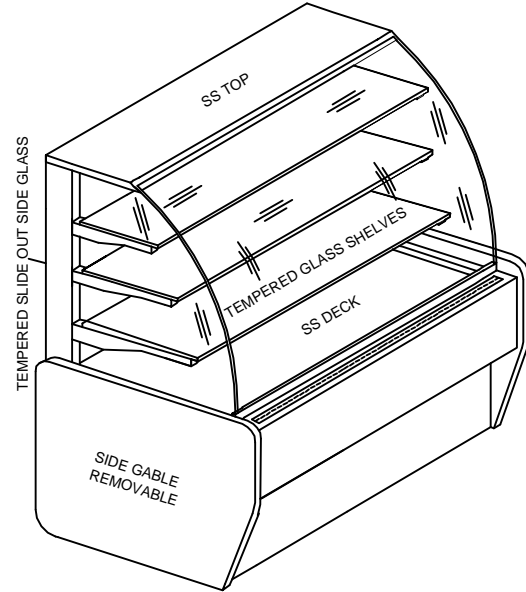
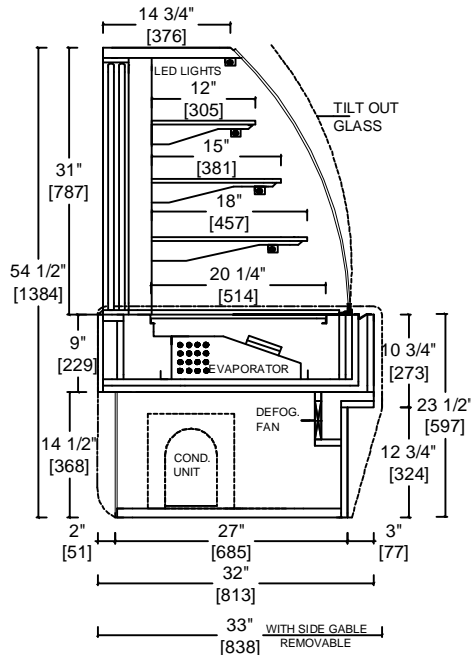

REAR VIEW 48" LONG UNIT SHOWN

SPECIFICATION

REFRIGERATED SELF CONTAINED

MODEL	LENGTH	H.P.	REF.	VOLTS	AMPS	PLUG	WT.
P2-38R	38"(965MM)	1/3	134A	115	9.0	5-15P	490
P2-48R	48"(1219MM)	1/2	134A	115	11.5	5-20P	570
P2-60R	60"(1524MM)	1/2	134A	115	12.0	5-20P	690
P2-74R	74"(1880MM)	1/2	134A	115	13.5	5-20P	780
P2-94R	94"(2388MM)	3/4	134A	115	14.0	5-20P	870

* All specification subject to change without notice.

** Case is designed to operate under normal store conditions of 24 degree C (75 degree F) with 50% R.H. Case must not be placed under direct sunlight, extreme temperature changes, air conditioning diffusers, rapid air currents ,ovens , ceiling fans etc. It will effect case temperature. Refrigerated Cases are designed to maintained pre chilled products. Products entering above 4 degrees Celsius (41 degrees Fahrenheit) can affect the temperature in the entire cabinet. Any adverse field conditions stated above will void warranty. Front glass can fog up under hot and humid conditions.



SMART COOLING CONCEPTS INC.

14 MELANIE DR., UNIT 11, BRAMPTON, ON, CANADA, L6T 4L3
 Tell: 905-458-5340, Fax: 905-458-4424, Toll Free: 1-855-458-5840
 smartcoolingconcepts.com. email:garysohi@smartcoolingconcepts.com